

Q 6 1.4T



25

8 1.4T

: ZL201220332872.4	[2012] 156
: ZL201220041902.6	[2012] 333
: ZL201210028744.5	JK [2012] 1050
: ZL20162025241.6	PCT CN2011/082524
: ZL201310335484.0	

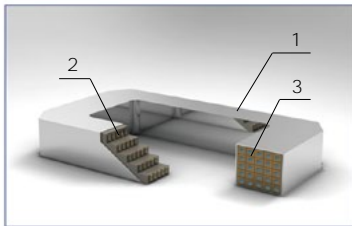

1 2 3

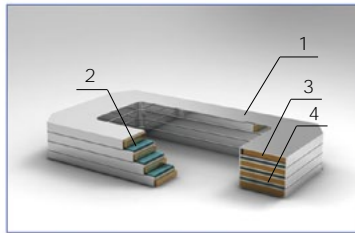

1 2 3 4

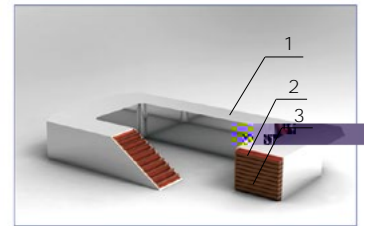

1 2 3

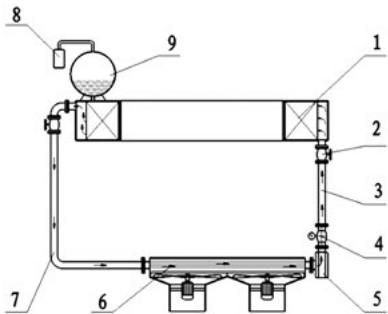

1.
2.
3.
4.
5.
6.
7.
8.
9.

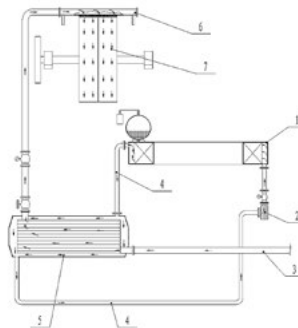

1-
2-
3-
4-
5-
6-
7-

	LHGC-1000F	LHGC-1250F	LHGC-1500F	LHGC-1750F	LHGC-2000F	LHGC-2250F	LHGC-2500F	LHGC-2750F	LHGC-3000F	LHGC-3500F	LHGC-4000F	LHGC-5000F
(T)	1.1/1.4(0.6)											
	2.0/2.4(1.1)											
kW	17/28(10)	19/40(12)	32/38(15.5)	37/55(23)	49/65(29)	51/70(32)	65/76(41)	69/92(42)	72/106(50)	93/139(52)	102/128(58)	120/138(75)
t/h	2 3.5	5 9	10 15	15 25	25 40	33 60	40 75	50 100	75 125	125 200	175 275	300 400
m ³ /h	12.5 20	20 50	50 100	75 150	100 200	160 300	200 400	200 500	350 650	550 1000	750 1400	1400 2000
A	41/85(70)	85/125(85)	110/130(110)	130/150(125)	140/180(130)	146/195(120)	165/206(120)	225/200(100)	185/270(150)	205/330(180)	256/345(205)	320/365(200)
%	10 35											
mm	- 1.2											
r/min	2 4											
mm	1000	1250	1500	1750	2000	2250	2500	2750	3000	3500	4000	5000
kW	1.1	1.5	3	4	5.5	7.5	11 7.5	15	18.5 15	30	37	55
DCV	0 514()											
Mpa	0.2 0.4											
m ³ /h	8 12	12 20	20 30	30 50	40 80	60 100	80 120	100 150	120 220	150 250	200 400	350 550
(t)	4/3(2)	4/6(3.5)	9.3/14(4)	15/8.5(9)	20/24(13)	24/30(16)	24/25(17)	21/26(18)	33/36(25)	50/52(47)	70/75(64)	80/85(74)
(mm)	2360	2780	3000	2970	3170	4400	3660	3915	4410	4900	5470	7100
	2510	2930	3050	3025	3240	4600	3840	4200	4510	5500	5700	7550
	2260	2680	2900	2870	3070	4300	3650	3910	4150	7400	5310	7000
	2700	3270	3320	3540	3810	4400	4690	4830	5540	5500	6240	7650
	2850	3420	3700	3900	4080	4600	5030	5130	5800	5900	6830	8000
	2600	3110	3220	3440	3710	4300	3785	3910	4630	7750	5910	7130
	2480	2850	3330	3710	4250	4600	5290	5760	6450	4400	8520	9500
	2630	3000	3650	4060	4480	4800	5500	5960	6610	5200	8650	9750
	2380	2750	3230	3610	4150	4150	5175	5650	6280	7200	8340	9380

1

1.4T

0.6T

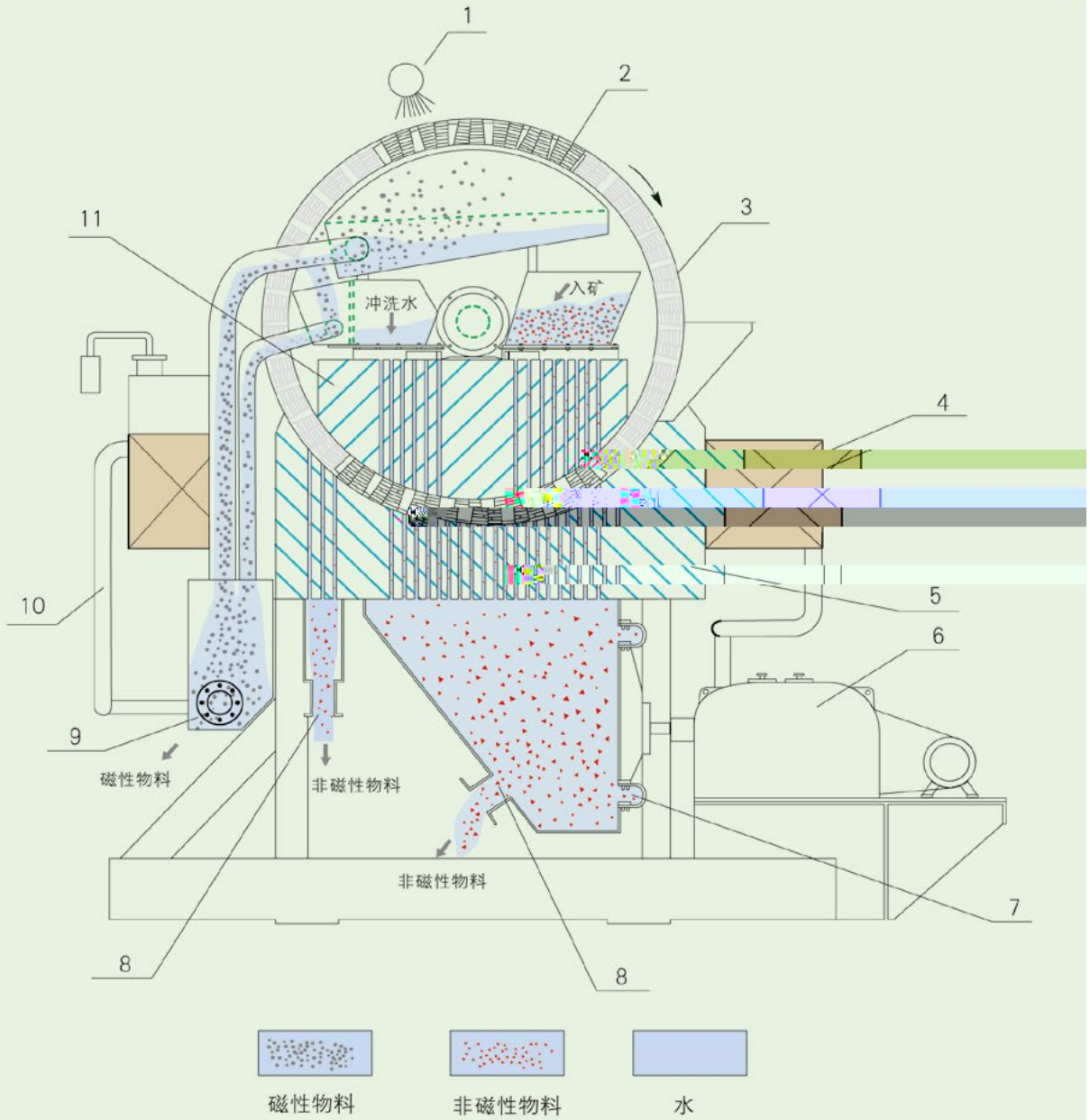

1. 卸矿水 2. 磁介质 3. 转环 4. 励磁线圈 5. 下磁极 6. 脉动装置
 7. 橡胶鼓膜 8. 非磁性物料出口 9. 磁性物料出口 10. 油冷系统 11. 上磁极

磁场对物料吸力的计算： $F_m = K \cdot X_s \cdot B \cdot \Delta H \cdot V$

(F_m —磁场对物料的吸力 K —吸力常数 X_s —比磁化系数 B —分选磁场强度 ΔH —分选磁场梯度 V —物料粒度)